



# expats CLUB

**Welcome to the  
Pattaya Expats Club  
Tuesday 25th June 2024**

A group of diverse graduates in black gowns and caps, smiling and celebrating outdoors under green trees. The graduates are of various ethnicities and are captured in a joyful moment, with some holding up their caps. The background is filled with lush green foliage, suggesting a campus setting.

# Stages of an International Baccalaureate (IB) Course

An Overview of the IB Programmes



# Introduction to IB



Purpose of IB  
Programmes

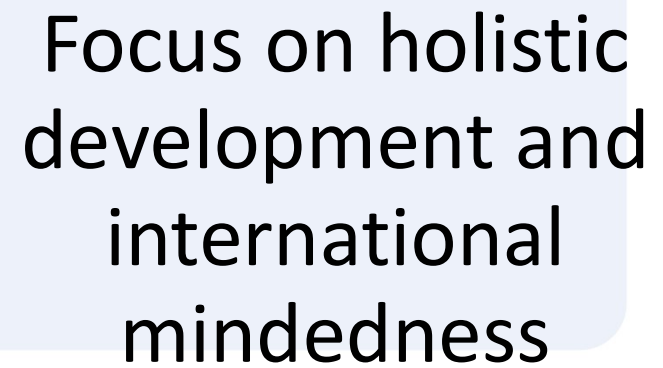

Focus on holistic  
development and  
international  
mindedness

---



## Primary Years Programme (PYP) Age Range: 3-12 years old

- Focus: Holistic development and inquiry based learning
- Six Transdisciplinary Themes:
  - Who we are
  - Where we are in place and time
  - How we express ourselves
  - How the world works
  - How we organize ourselves
  - Sharing the planet

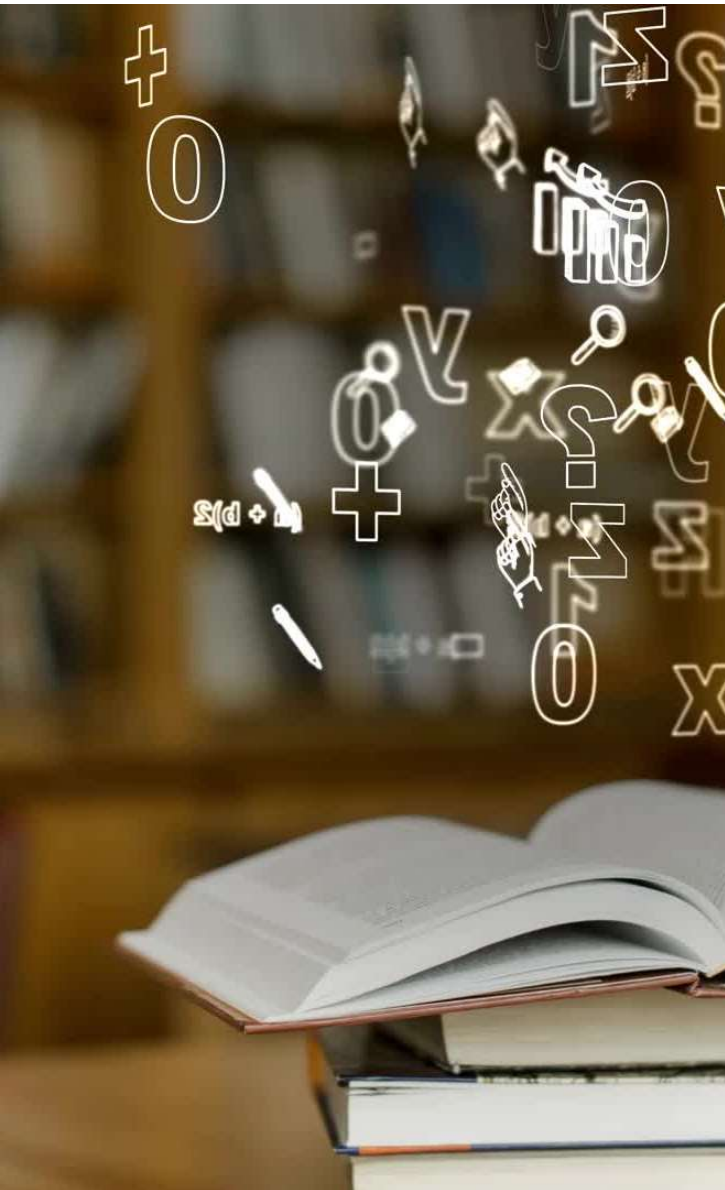

# Middle Years Programme (MYP)

## Age Range: 11-16 years old

Focus: Academic challenge and practical connections

- Eight Subject Groups:
  - Language Acquisition
  - Language and Literature
  - Individuals and Societies
  - Sciences
  - Mathematics
  - Arts
  - Physical and Health Education
  - Design
- Personal Project requirement



## Diploma Programme (DP) Age Range: 16-19 years old

Focus: Rigorous preuniversity course

- **Six Subject Groups** (must choose 1 from each group)
  - Studies in Language and Literature
  - Language Acquisition
  - Individuals and Societies
  - Sciences
  - Mathematics
  - The Arts

*Instead of a subject from The Arts, a student can choose an additional subject from one of the other groups.*



## Diploma Programme (DP)

Age Range: 16-19 years old

### Core Components:

- Extended Essay (4,000 word research paper)
- Theory of Knowledge (TOK)
- Creativity, Activity, Service (CAS)

## Career-related Programme (CP) Age Range: 16-19 years old

Focus: Career-related learning and academic rigor

- Combination of DP courses and career-related studies
- CP Core Components:
  - Reflective Project
  - Language Development
  - Service Learning
  - Personal and Professional Skills





# Career-related Programme (CP)

## 1. Core Components:

1. **Personal and Professional Skills:** Focuses on developing skills needed for lifelong learning and employment.
2. **Service Learning:** Involves students in community service to develop social awareness and a sense of responsibility.
3. **Reflective Project:** An in-depth body of work produced over an extended period, reflecting on an ethical issue related to the student's career-related studies.
4. **Language Development:** Aims to ensure that students have the necessary language skills to communicate in a global society.





# Career-related Programme (CP)

## **2.Career-related Studies:**

These are courses related to a particular career path,

- provided by an external provider or
- developed in collaboration with the school.
- They are designed to provide students with both practical and theoretical knowledge in their chosen field.

## **3.Diploma Programme Courses:**

- Students must take at least two Diploma Programme (DP) courses,
- which provide academic rigor and
- prepare students for further education and work.

## Career-related Programme (CP)

Age Range: 16-19 years old

### **Holistic Development:**

- The CP aims to develop students who are knowledgeable, principled, open-minded, and reflective,
- balancing academic and career-related learning
- with personal development.



---

## IB Learner Profile

### Attributes of IB Learners:

- Inquirers
- Knowledgeable
- Thinkers
- Communicators
- Principled
- Openminded
- Caring
- Risktakers
- Balanced
- Reflective





# Conclusion

Importance of holistic development and international-mindedness



# expats CLUB

**Welcome to the  
Pattaya Expats Club  
Tuesday 25th June 2024**

## Battery

Electric Vehicle

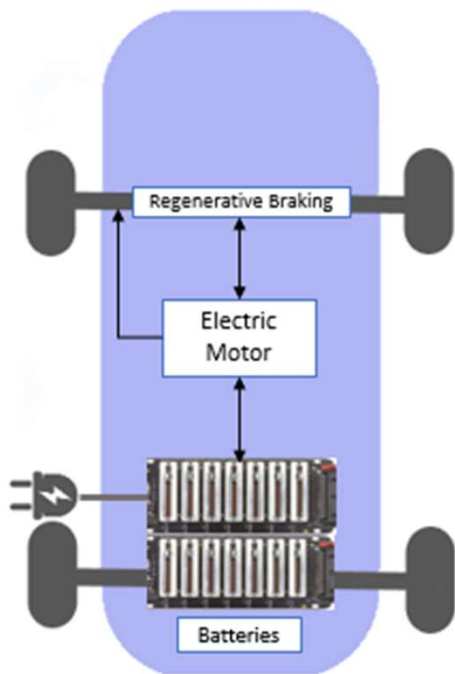

## Plug-In Hybrid

Electric Vehicle

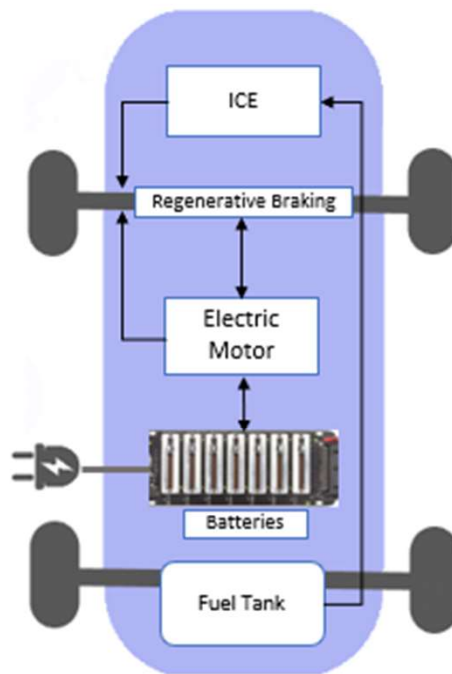

## Hybrid

Electric Vehicle

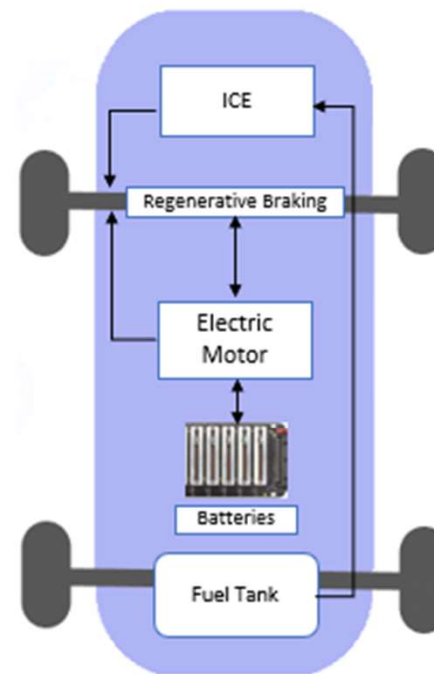

## Fuel Cell

Electric Vehicle

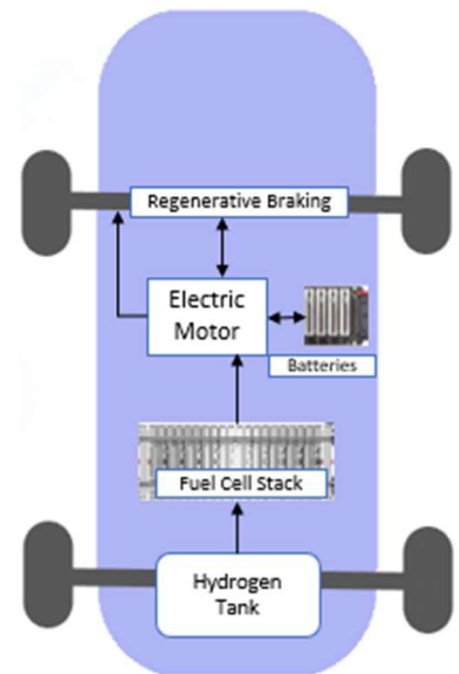

## Series HEV

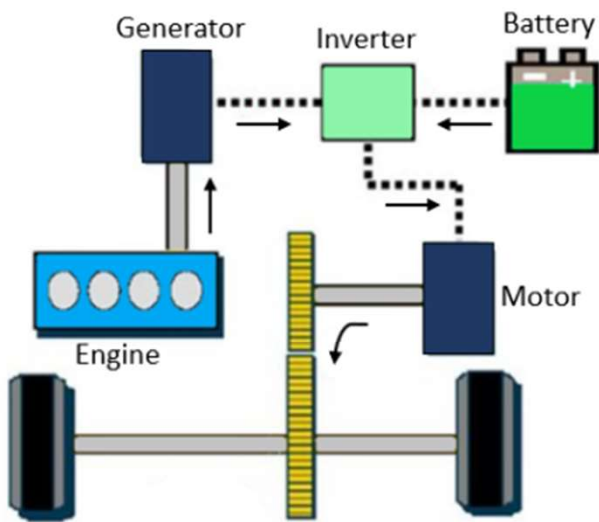

## Parallel HEV

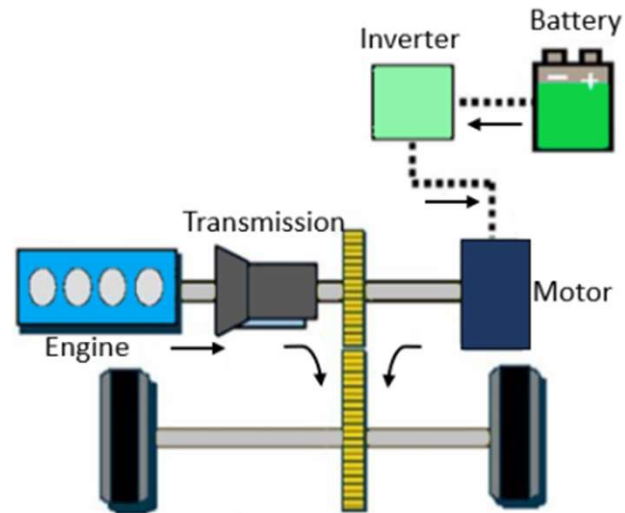

## Series-Parallel HEV

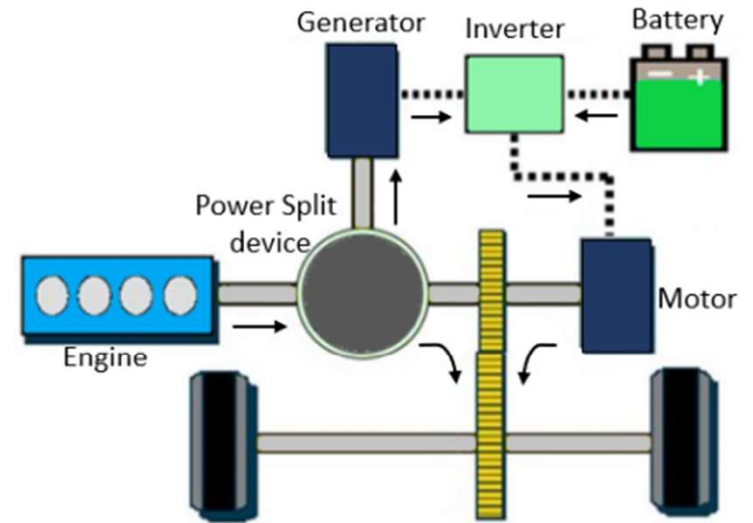



# Regenerative Braking

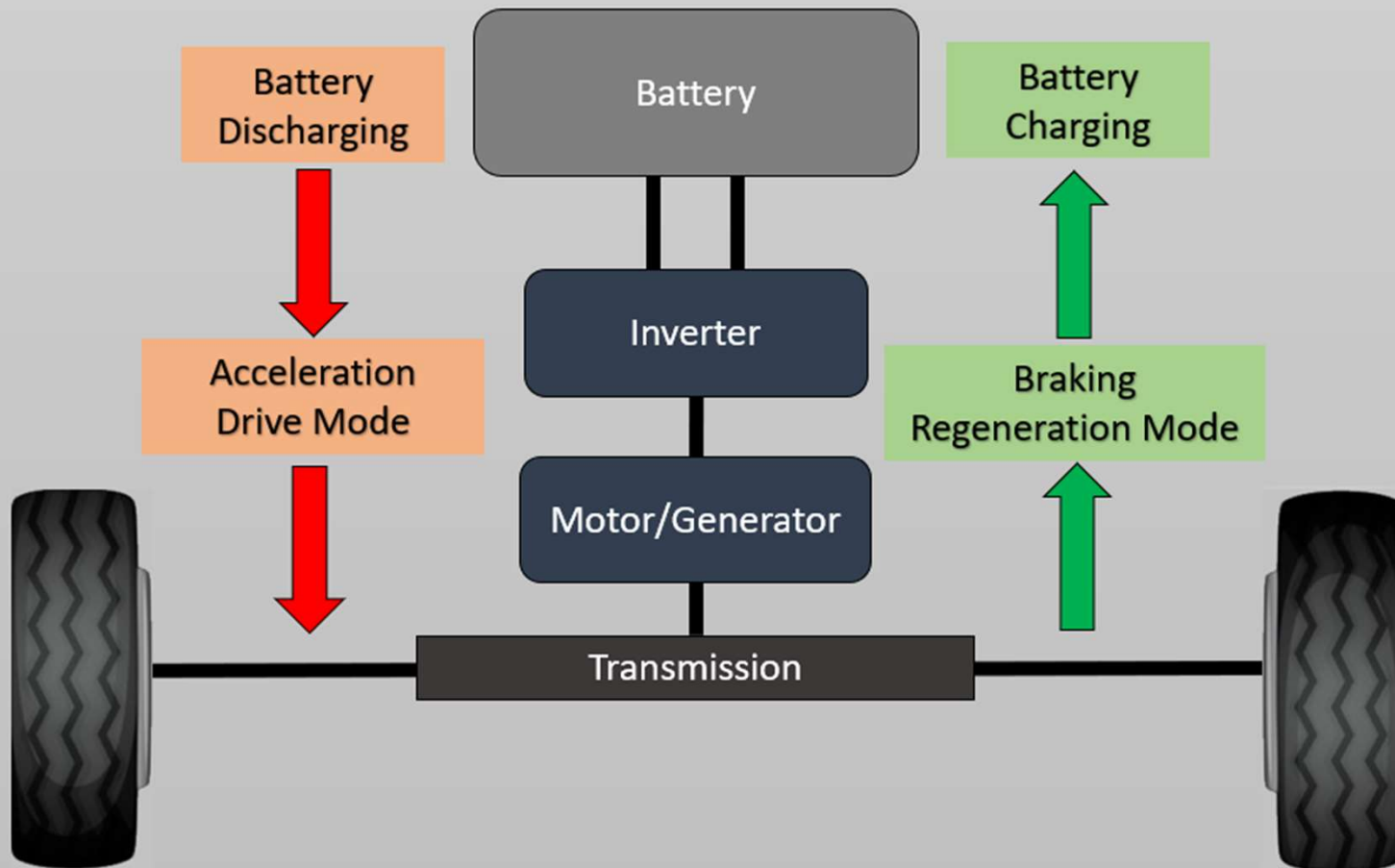

### Level 1 charging



Voltage:  
120V

Charge Time:  
3 - 5 miles per hour

Locations:  
Home

### Level 2 charging



Voltage:  
240V

Charge Time:  
12 - 40 miles per hour

Locations:  
Home, Public

### Level 3 charging



Voltage:  
480V

Charge Time:  
80% charge in 20-30 mins

Locations:  
Public

Watch out,  
you're not  
welcome





# expats CLUB

**Welcome to the  
Pattaya Expats Club  
Tuesday 25th June 2024**



What Does Your Poo &  
Henry VIII Have In Common

**TYPE 1**



**Separate hard lumps**

VERY CONSTIPATED

**TYPE 2**



**Lumpy and sausage like**

SLIGHTLY CONSTIPATED

**TYPE 3**



**A sausage shape with cracks in the surface**

NORMAL

**TYPE 4**



**Like a smooth, soft sausage or snake**

NORMAL

**TYPE 5**



**Soft blobs with clear-cut edges**

LACKING FIBER

**TYPE 6**



**Mushy consistency with ragged edges**

INFLAMMATION

**TYPE 7**



**Liquid consistency with no solid pieces**

INFLAMMATION AND DIARRHEA



# expats CLUB

**Welcome to the  
Pattaya Expats Club  
Tuesday 25th June 2024**



# Pattaya Expats Club

Expats Helping Expats to Live Legally in Thailand

- Home
- Next Meeting
- Latest News, Tips & Tricks
- Recommended Services
- Sponsors
- Recent Speakers
- Membership
- Useful Info/FAQ
- Death/Dying
- Insurance
- About Us

## Home

**PATTAYA**

Search ...

Pattaya Expats



# Latest News, Tips & Tricks

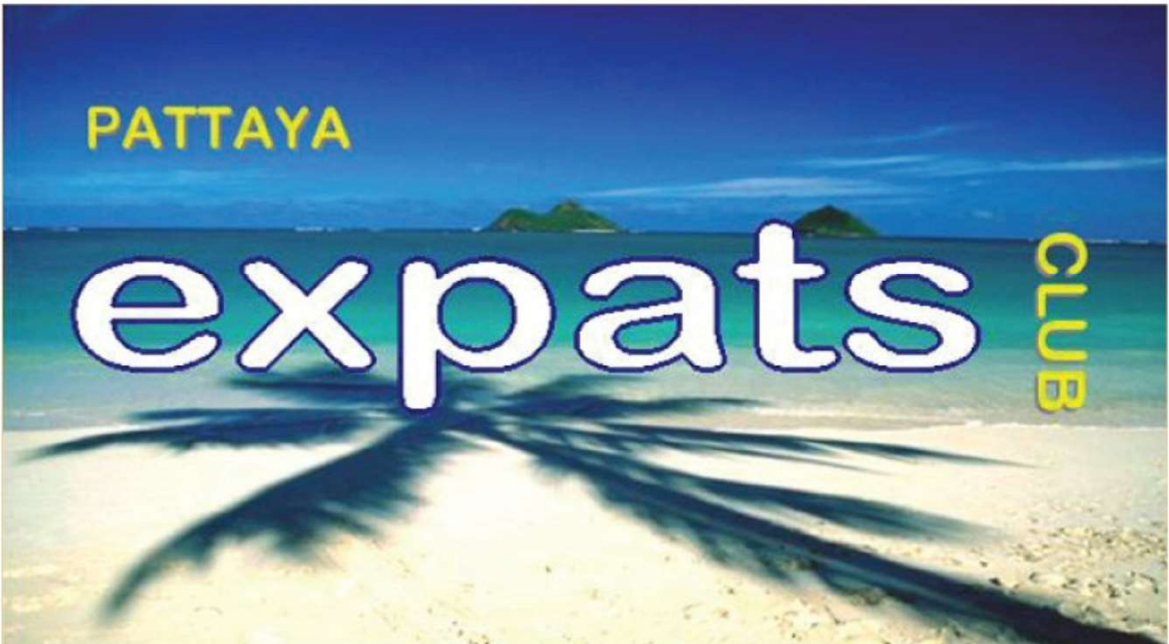



Search ...

## Pattaya Expats Club

Name

Email

The image shows a digital interface for the Pattaya Expats Club. At the top is a search bar with the placeholder text 'Search ...'. Below it is a dark blue rectangular box containing the club's name 'Pattaya Expats Club' in white serif font. Underneath the name are two white input fields for 'Name' and 'Email'. At the bottom of this box are four social media icons: an envelope for email, the Facebook 'f' logo, the YouTube logo, and the WhatsApp logo.

## Some Useful Tips & Tricks from Recent Meetings

1. [Voice Typing](#)
2. [Microsoft Translator](#)
3. [Immigration Forms Guidance](#)
4. [General Immigration Visa Requirements](#)
5. [True Move Add Value Codes](#)
6. [DTAC Add Value Codes](#)
7. [Documents Required for 90 Day Reporting](#)
8. [Chicken Tikka & Cheap Spirits](#)
9. [Bottled Water Waste & Water Filters](#)
10. [Real Milk](#)
11. [Water Activity & Food Preservation](#)
12. [Insomnia, Antihistamines, Google Lens, Screenshot, Old Phone](#)
13. [Long Term Resident Visa](#)
14. [New Visa Measures, Non-O-X Visa, QR code scams](#)
15. [Co-Pilot Image Creations, ChatGPT Manipulations, HelioBacter, Euro 2024](#)

Click on the logos to find the websites.



✍️ Compose

📁 Inbox 1,062

★ Starred

🕒 Snoozed

📂 Important

▶ Sent

🕒 Spam 12

📂 Categories

▼ More

Labels +

📁 [Imap]/Sent

📁 Boxer

📁 Junk

▼ More

## Some Useful Tips & Tricks from Recent Meetings

[Voice Typing](#)

[Microsoft Translator](#)

[Immigration Forms Guidance](#)

[General Immigration Visa Requirements](#)

[True Move Add Value Codes](#)

[DTAC Add Value Codes](#)

[Documents Required for 90 Day Reporting](#)

[Chicken Tikka & Cheap Spirits](#)

How to eliminate [Bottled Water Waste](#)

[Real Milk](#)

[Water Activity & Food Preservation](#)

[Insomnia, Antihistamines, Google Lens, Screenshot, Old](#)

24 June 2024

Mon 14:11 (Local time)

Mon 08:11 (Jamie)

Mon 17:11 (Ross)



# expats CLUB

**Welcome to the  
Pattaya Expats Club  
Tuesday 25th June 2024**